

# DALI PIR

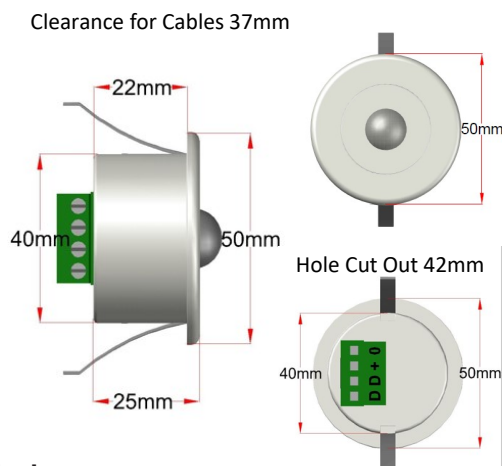

The DaliLUX DALI PIR is a sensor for automatic lighting control. It detects movement using a PIR sensor, which updates the light controller using a DALI interface. When an area is no longer occupied, the device times out after a configurable period. This detector features our Progressive Sensitivity function to eliminate false triggering. There is also an integral lux detector, enabling the sensor to control daylight linking. Daylight linking can be configured either to keep lights off when there is sufficient ambient light, or used as part of a closed loop to maintain a pre-set luminance level in a dimmable system. The PIR can also be specified with custom painted bezels if required.

## Also available in a high bay configuration



## Lux Detector

When using the lux detector, an extra DALI address is assigned to the unit. The PIR ID is randomised during commissioning and there is a visual alert showing when a PIR has not been addressed. The walk-test mode, indicated by a built-in LED, assists when configuring the detector.

Supply voltage	10-18 VDC
Power Consumption	120mW
Range	6m at 2.8m ceiling height
Max number of devices (2-wire connection)	10
Max number of devices (4-wire connection)	15
Fitting hole size	42mm
Material (body of unit)	Flame retardant ABS
Material (clear lens)	Clear acrylic (PMA)
Standard colour	RAL9010
Temperature range	-10°C to 35°C
Max humidity	90% CH (non-condensing)

**IMPORTANT:** Information contained in this datasheet is subject to change at any time without notice. Installation guides are available - call us on 020 087 8084.

## Part Number:

**DLLX-DALIPIR2**

**DLLX-DALIPIR2/BLK**

**DLLX-DALIPIR2/IP**

**DLLX-DALIPIR2/HB**

**White**

**Black**

**IP65 Rated**

**High Bay**



- Connected via a screw terminal on the rear in a standard DALI two wire configuration
- Powered from the data line.
- For applications where the current drain would be too high for the bus, PIRs can be powered from the DALI64 using a 4-wire connection.

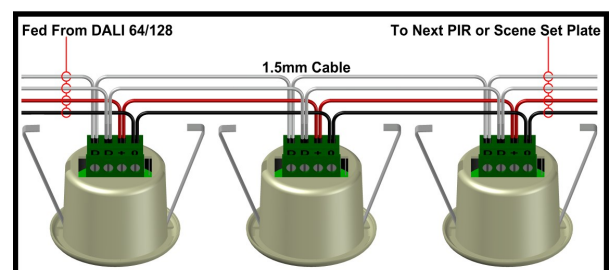

## Detection Range 6m at 2.8m Ceiling Height

